

SECTION A-A

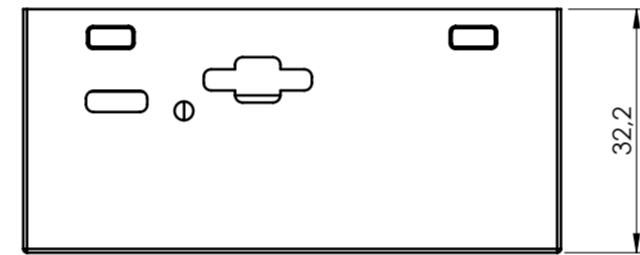

BODY ENCLOSURE

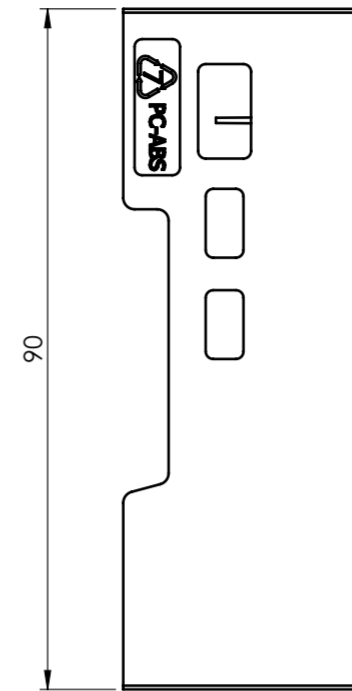
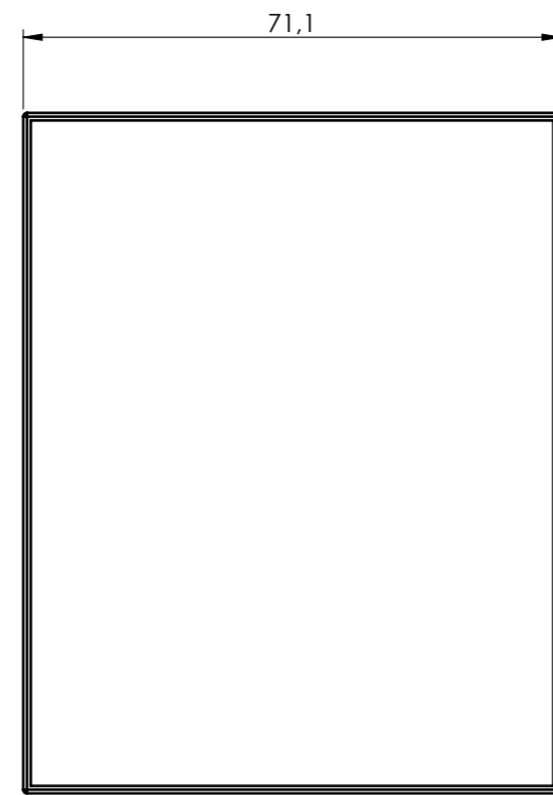
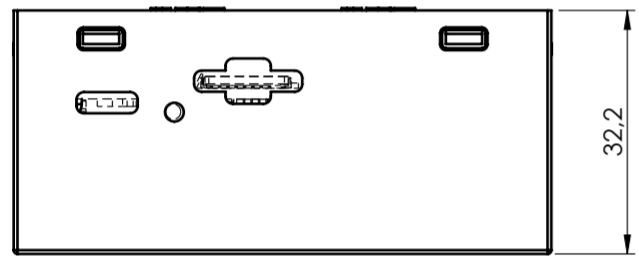
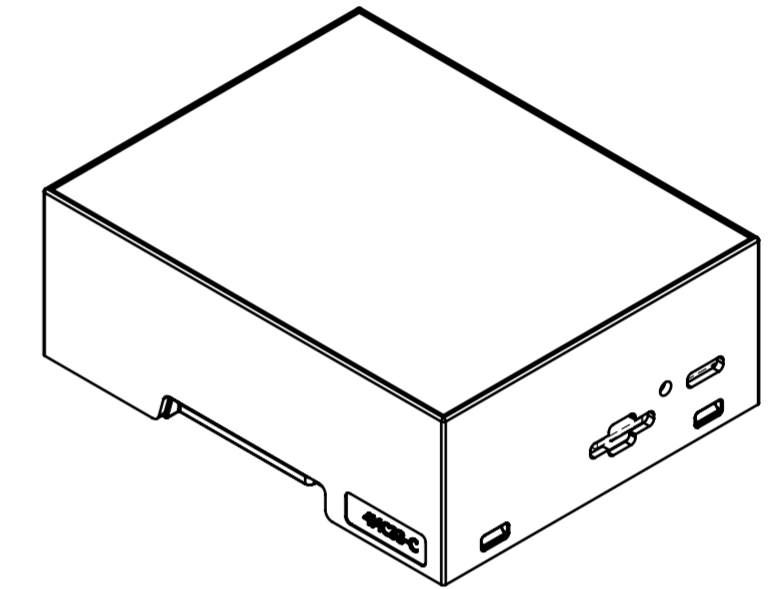
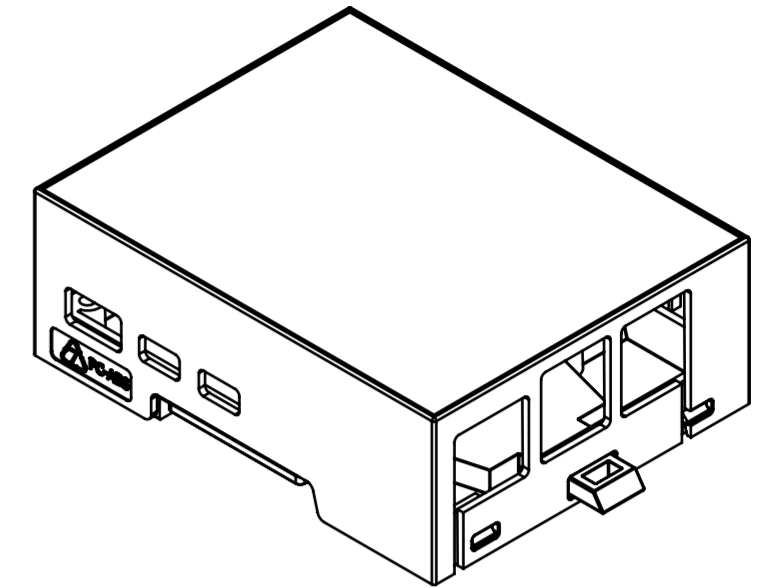

BASE

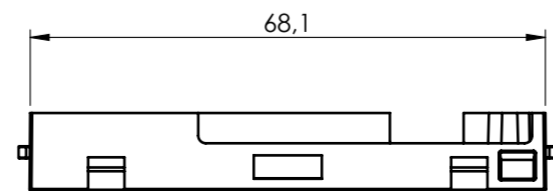
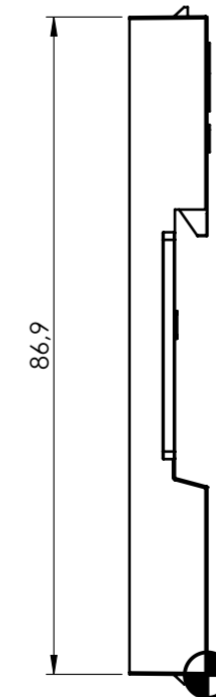
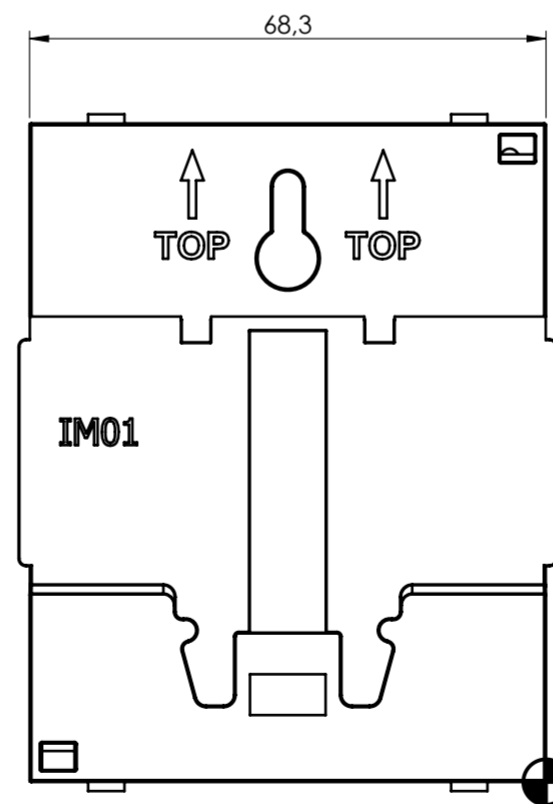

General information:  
 - Workpiece zero point for mechanical processing  
 - Minimum recommended radius for machining = R1.0 mm  
 - Mounting rail like EN 60715: TH 35-7.5 or TH 35-15  
 - Recommended PCB outline on [www.italtronic.com](http://www.italtronic.com)

HOOK

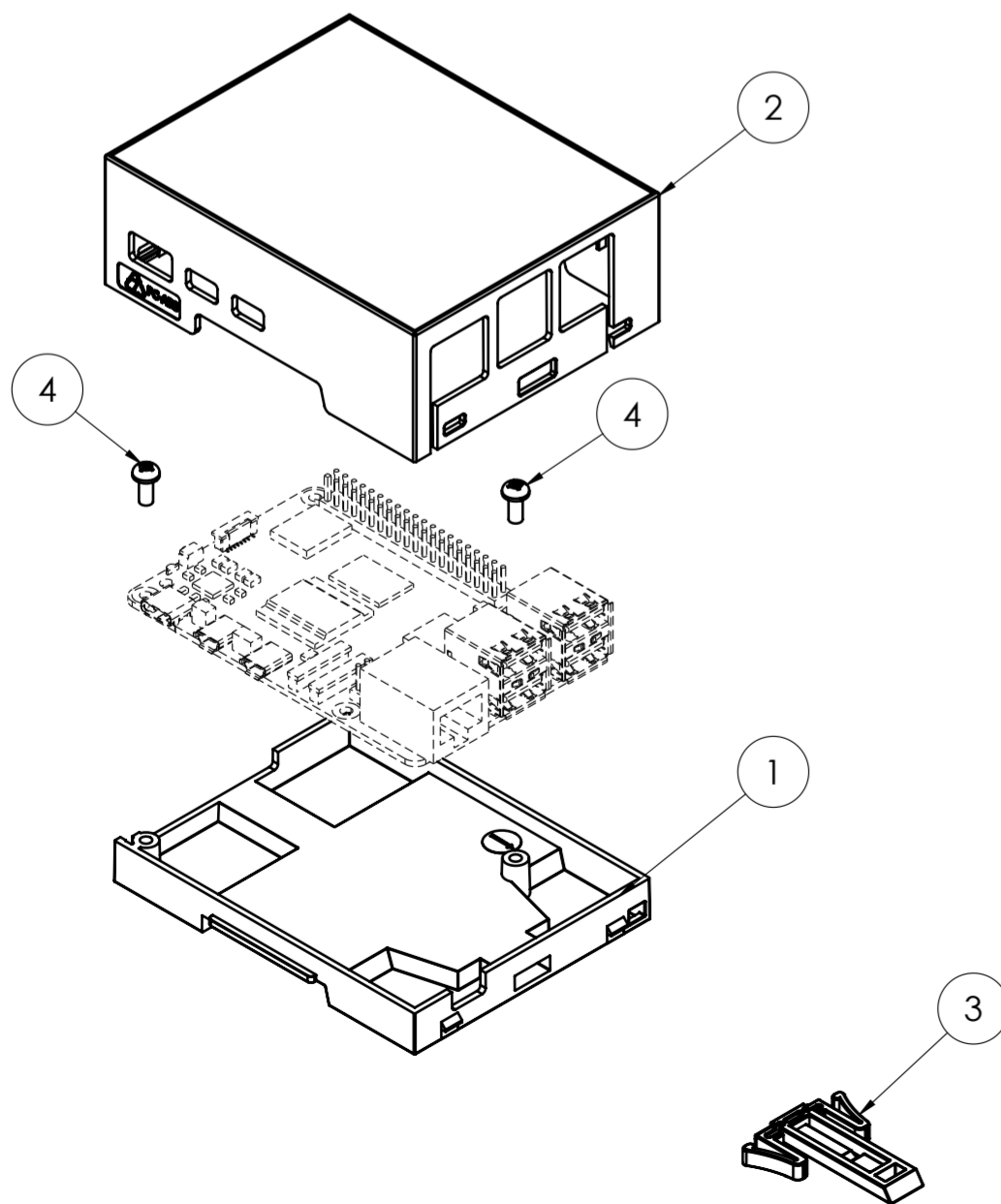
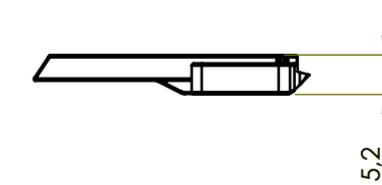
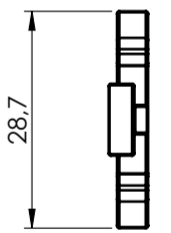
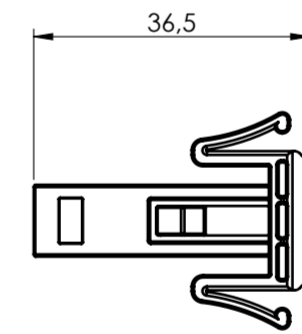

RIF.	Q.TY	DRAWING	DESCRIPTION
1	1	2_050_00025	BASE MODULBOX XT-XTS 4M
2	1	2_050_00065	BODY 4MC33-C XTS COMPACT P15
3	1	2_250_00072	HOOK FOR MODULBOX XT-XTS
4	2	8_100_00003	SCREW d 2.9 X 6.5 TC+ TRUNK-POINT

General Tolerance UNI EN 22768/1 Media (m)					Sheet:
from 0.5 to 3	from 3 to 6	from 6 to 30	from 30 to 120	from 120 to 400	1
± 0.1	± 0.1	± 0.2	± 0.3	± 0.5	
Scale:	IM:	Drawn:	Checked:	Date:	Material:
1:1	--	M.S.	R.N.	25/03/2024	Process:
Dimension in mm		Replaces the:		Derived from:	Weight:
		M-06755-00		--	gr
Description:					Cod. Mold:
KIT 4M COMPACT XTS P15					--
KIT 4M COMPACT XTS P15					
Drawing nr.:					Rev.:
3_050_00066					- A2