

SECTION A-A

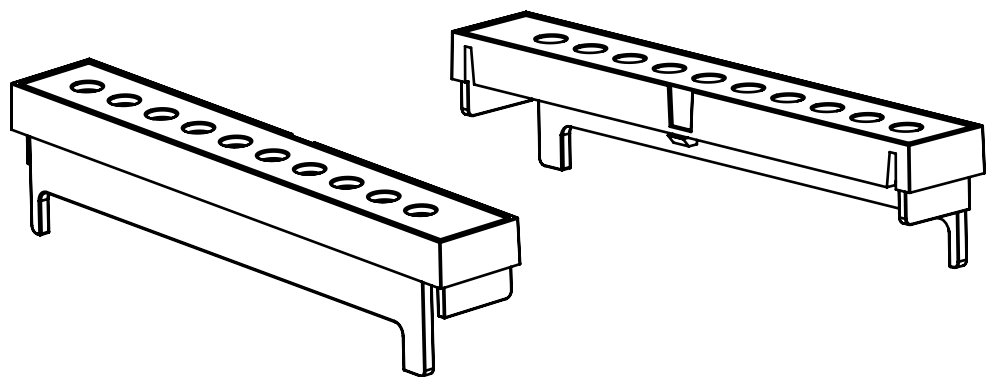

General information:

- Workpiece zero point for mechanical processing
- Minimum recommended radius for machining = R1.0 mm

General Tolerance UNI EN 22768/1 Media (m)					Sheet:	
from 0.5 to 3 ± 0.1	from 3 to 6 ± 0.1	from 6 to 30 ± 0.2	from 30 to 120 ± 0.3	from 120 to 400 ± 0.5	1	
Scale: 1:1	Drawn: M.S.	Checked: R.N.	Date: 12/06/2023	Material: PC/ABS	Process: INJECTION	
Dimension in mm 				Weight: 5.01 gr	Cod. Mold: ST.05CN002	
Description: COPRIMORSETTO PREFORATO PASSO 7,65 10 VIE 5MP7,5 TERMINAL COVER MODULBOX PRE-HOLED PITCH 7,65 10 POLES				Derived from: --		
Drawing nr.: 2_250_03737				Rev.: 00 A4		