

SECTION A-A

LOWER CNC TURRETS

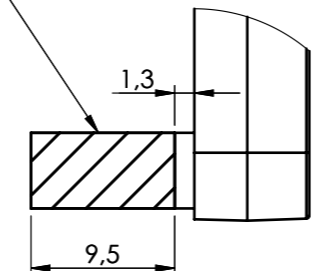

DETAIL B
SCALE 2 : 1

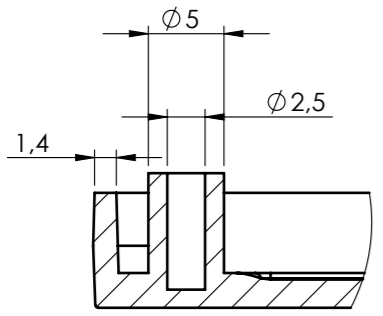
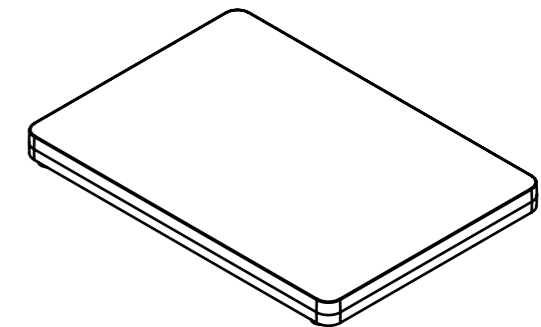

DETAIL C
SCALE 2 : 1

General information:
 - Workpiece zero point for mechanical processing
 - Minimum recommended radius for machining = R1.0 mm

General Tolerance UNI EN 22768/1 Media (m)					Sheet:
from 0.5 to 3 ± 0.1	from 3 to 6 ± 0.1	from 6 to 30 ± 0.2	from 30 to 120 ± 0.3	from 120 to 400 ± 0.5	1
Scale: 1:1	Drawn: R.N.	Checked: R.N.	Date: 20/03/2023	Material: ABS	Process: CNC
Dimension in mm	Derived from: 2_010_00004			Weight: 19.80 gr	Cod. Mold: --
 enclosures for electronics italtronic.com					Description: PANNELLO CHIUSO PER MANOPOLE BASE H15 CLOSED PANEL FOR HANDLES BASE H15
Drawing nr.: 2_010_00005				Rev.:	A3